

## Instructions For Use

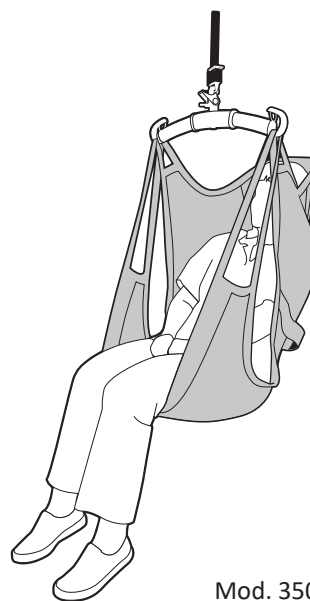

Mod. 300



Mod. 350

## Product Description

Liko ComfortSling Plus provides a comfortable sitting position and safe patient transfer between, e.g. the bed and wheelchair. It adapts to suit the patient and no individual adjustments are required. A properly fitted and carefully applied ComfortSling Plus provides the patient with a good sense of security and a high degree of comfort, along with good back and head support (Mod. 350).

ComfortSling Plus is gentle to apply since the patient is in a supine position during the application and the sling remains in the chair after the transfer. When the patient later is ready to be moved back to bed, the sling is already in place. The strap loops can then easily be connected to the sling bar and the lift can do the work.

ComfortSling Plus is suitable for patients who are especially sensitive due to muscle or joint pain.

ComfortSling Plus is often suitable even for amputees because it provides support under the entire sitting surface.

ComfortSling Plus High (Mod. 350) are equipped with built-in head support and provide a comfortable reclined sitting position. It is highly suitable for patients who have poor torso and head stability.

*In this document, the person being lifted is referred to as the patient and the person helping them is referred to as the caregiver.*

### **IMPORTANT!**



















Lifting and transferring a patient always involves a certain level of risk. Read the instructions for use for both the patient lift and lifting accessories before use. It is important to completely understand the contents of the instructions for use. The equipment should only be used by trained personnel. Ensure that the lifting accessories are suitable for the lift used. Exercise care and caution during use. As a caregiver, you are always responsible for the patient's safety. You must be aware of the patient's ability to make it through the lifting situation. If something is unclear, contact the manufacturer or supplier.

# Table of Contents

Symbol Description .....	3
Safety Instructions .....	4
Care and Maintenance .....	5
Definitions .....	5
How to Attach a Sling to Different Sling Bars.....	6
How to Attach a ComfortSling Plus to a Sling Bar with 4 Hooks (Twin Bars and Cross Bars) .....	7
Lifting from a Supine Position.....	7
Returning to the Supine Position.....	8
Removing the Sling.....	8
Lifting from the Floor.....	8
Lifting to a Wheelchair .....	9
Lifting from a Wheelchair .....	9
Different Sitting Positions Depending on Choice of Sling Bar .....	9
Different Sling Bars .....	10
Accessories .....	10
Overview Liko™ ComfortSling Plus Mod. 300, 350.....	11
Recommended Combinations .....	12

## Symbol Description

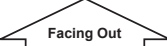
These symbols can be found in this document and/or on the product.

Symbol	Description
	Warning; this situation requires extra care and attention
	Read instructions for use before use
	CE mark
	Legal manufacturer
	Date of manufacturing
	Product Identifier
	Serial Number
	Medical device
	Do not dry clean
	Do not iron
	Tumble drying
	Do not tumble dry
	Washing Symbol is always in combination with recommended temperature in °C and °F.
	Latex Free
	Periodic inspection
	Do not bleach
	Line drying in shade
	Direction upwards and symbol on outside of equipment.
	Symbol on outside of equipment.
	GS1 Data Matrix Barcode that may contain following information. (01) Global Trade Item Number (11) Production Date (21) Serial Number

## Safety Instructions

### Before lifting, keep the following points in mind:

- A responsible person within your organization should decide on a case-by-case basis whether one or more caregivers are needed.
- Ensure that the sling selected meets the patient's needs with reference to model, size, fabric and design.
- For safety and hygiene reasons, use individual slings.
- Plan the lifting operation so that it can be done as safely and smoothly as possible.
- Check that the lifting accessory hangs vertically and can move freely.
- Although Liko's slingbars are equipped with latches, special caution must be exercised. Before the patient is lifted from the underlying surface, but after the straps have been fully extended, make sure the straps are correctly connected to the sling bar hooks.
- Make sure the patient is sitting securely in the sling before transferring to another location.
- Never lift a patient higher off the underlying surface than is needed to complete the lifting and transfer procedure.
- Never leave a patient unattended during a lifting situation.
- Make sure that the wheels on the wheelchair, bed, gurney, etc., are locked during the lifting/transfer operation.
- Always work ergonomically. Use the patient's ability to actively participate in the operations.
- When the sling is not being used, do not place in direct sun light.

 **Incorrect attachment of sling to slingbar may cause severe injury to the patient.**

 **Manually turning the patient in bed may cause injuries to the caregiver.**

 Medical Device Class I Product

**PATENT [www.hillrom.com/patents](http://www.hillrom.com/patents)**

**May be covered by one or more patents. See above Internet address.**

The Hill-Rom companies are the proprietors of European, US, and other patents and pending patent applications.

### Product Changes

Liko® products undergo continuous development, which is why we reserve the right to make product changes without prior notice. Contact your Hill-Rom representative for advice and information about product upgrades.

### Design and Quality by Liko in Sweden

Liko is quality certified according to ISO 9001 and its equivalent for the medical device industry ISO 13485. Liko is also certified according to environmental standard ISO 14001.

### Notice to Users and/or Patients in EU

Any serious incident that has occurred in relation to the device, should be reported to the manufacturer and the competent authority of the Member State in which the user and/or patient is established.

## Care and Maintenance

Inspect the sling before each use. Inspect the following points with regard to wear and damage:

- Fabric
- Straps
- Seams
- Loops

**⚠ Do not use damaged lifting accessories.**

If anything is unclear, please contact the manufacturer or supplier.

**Washing instructions:** Please see the sling's product label and the attached appendix "Care and Maintenance of Liko Slings".

### Periodic Inspection

The product must be inspected at least once every 6 months. More frequent inspections might be required if the products are used or washed more often than normal. For protocols please contact your Hill-Rom representative.

### Expected Life Time

The product has an expected life time of 1-3 years during normal use. Life time varies depending on material, use frequency, washing procedure, and weight carried. For protocols please contact your Hill-Rom representative.

### Recycling Instructions

The entire sling, including laths, padding material, etc. should be sorted as Combustible waste.



Hill-Rom evaluates and provides guidance to its users on the safe handling and disposal of its devices to aid in the prevention of injury, including, but not limited to: cuts, punctures of the skin, abrasions, and any required cleaning and disinfection of the medical device after use and prior to its disposal. Customers should adhere to all federal, state, regional, and/or local laws and regulations as it pertains to the safe disposal of medical devices and accessories.

If in doubt, the user of the device shall first contact Hill-Rom Technical Support for guidance on safe disposal protocols.

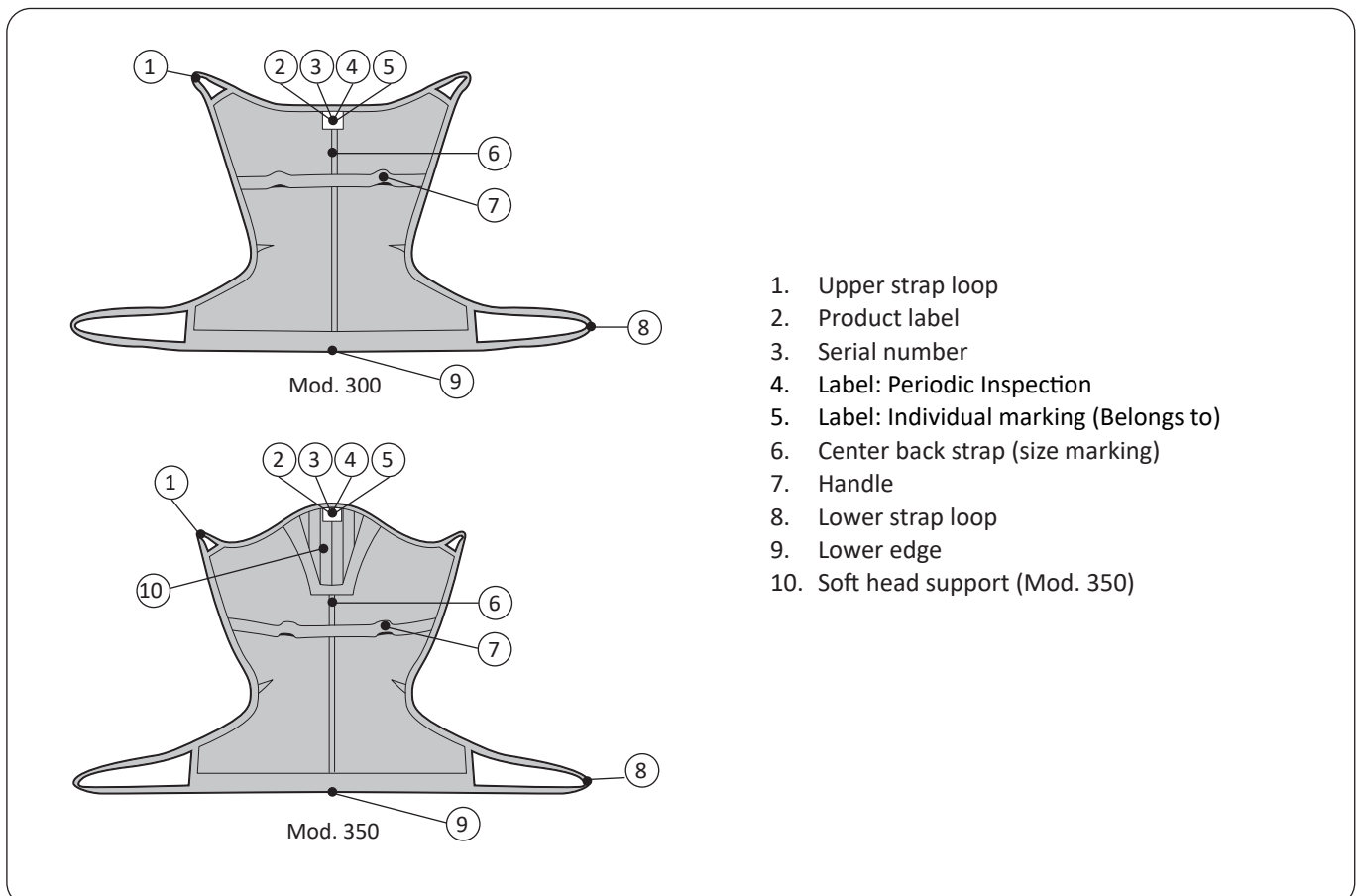
## Definitions

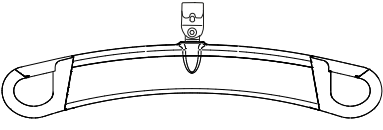
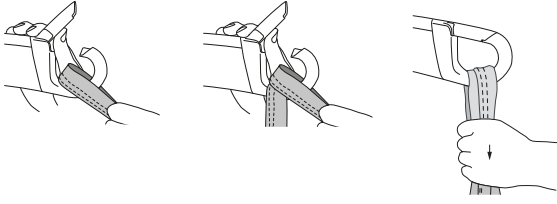
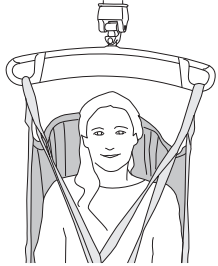
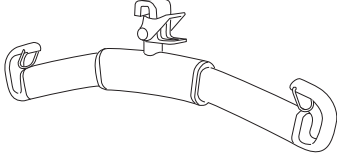
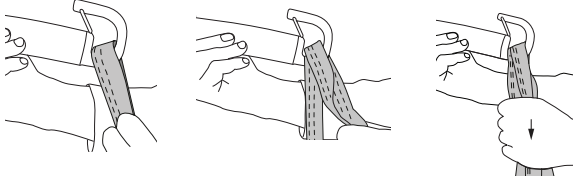

## How to Attach a Sling to Different Sling Bars

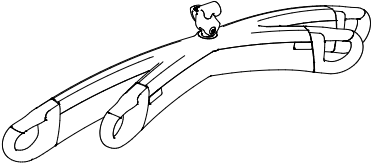
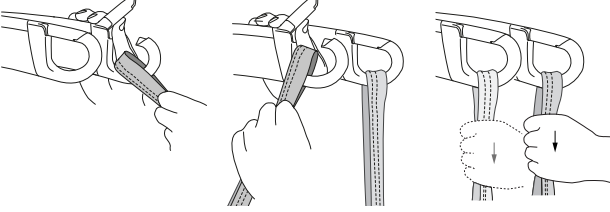
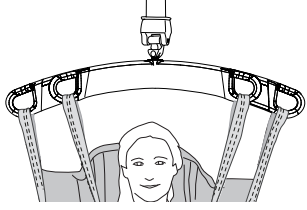
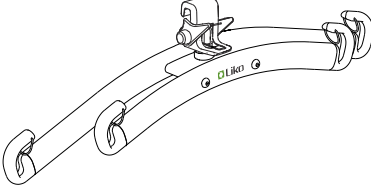
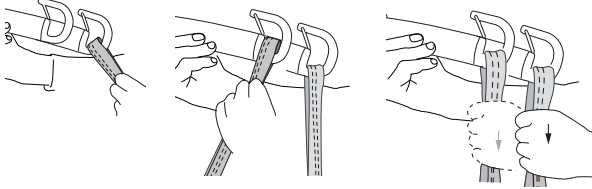
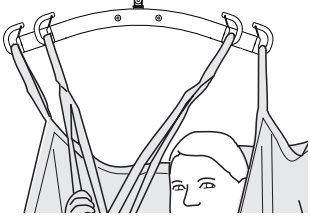
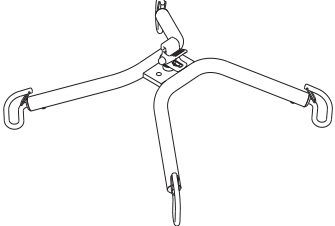
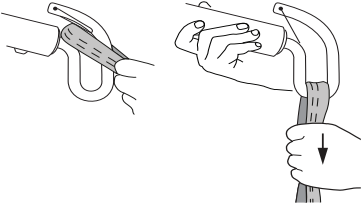
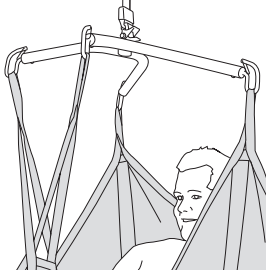
Sling bar	Sling loops to sling bar hooks	Correct
 <p>SlingGuard™</p>		
 <p>Universal</p>		
 <p>SlingGuard™ Twin</p>		
 <p>Universal Twin</p>		
 <p>Cross-bar</p>		

### Wrong!

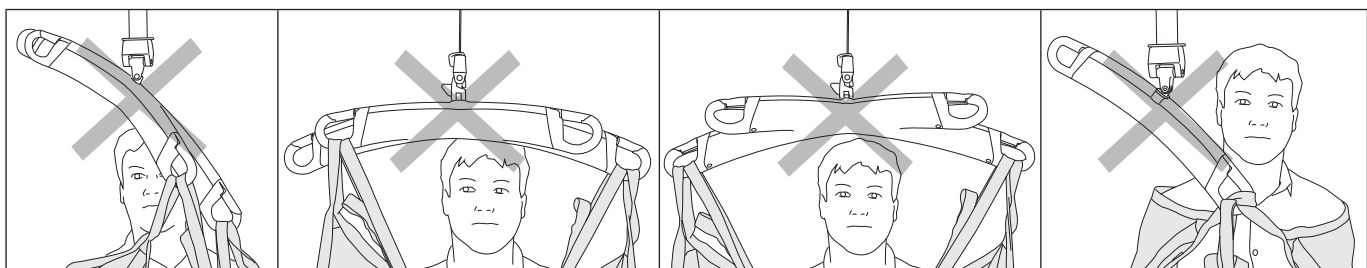

## How to Attach a ComfortSling Plus to a Sling Bar with 4 Hooks (Twin Bars and Cross Bars)

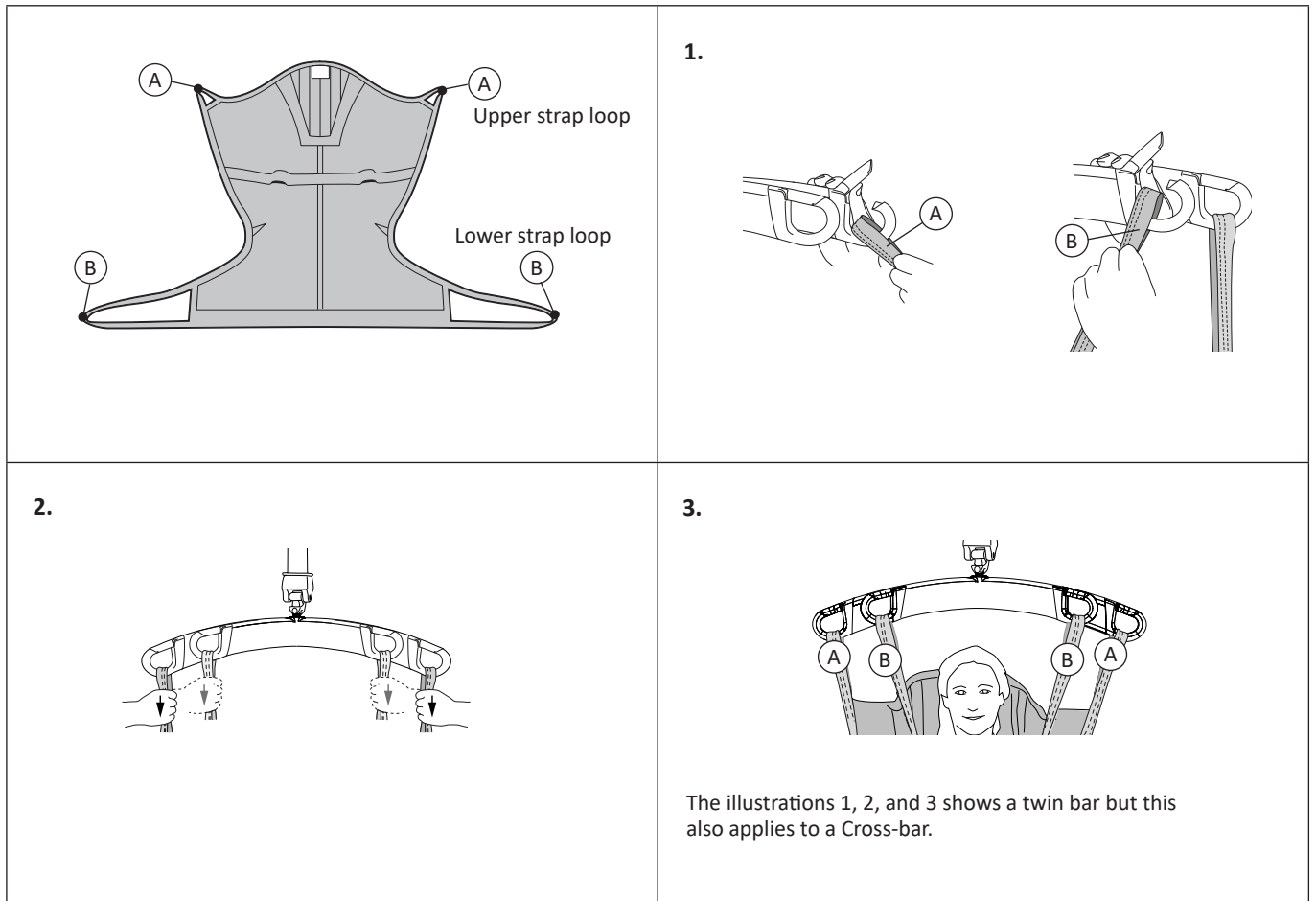

## Lifting from a Supine Position

Think about your own work posture as well as the comfort of the patient. Use the bed's raising and lowering functions.

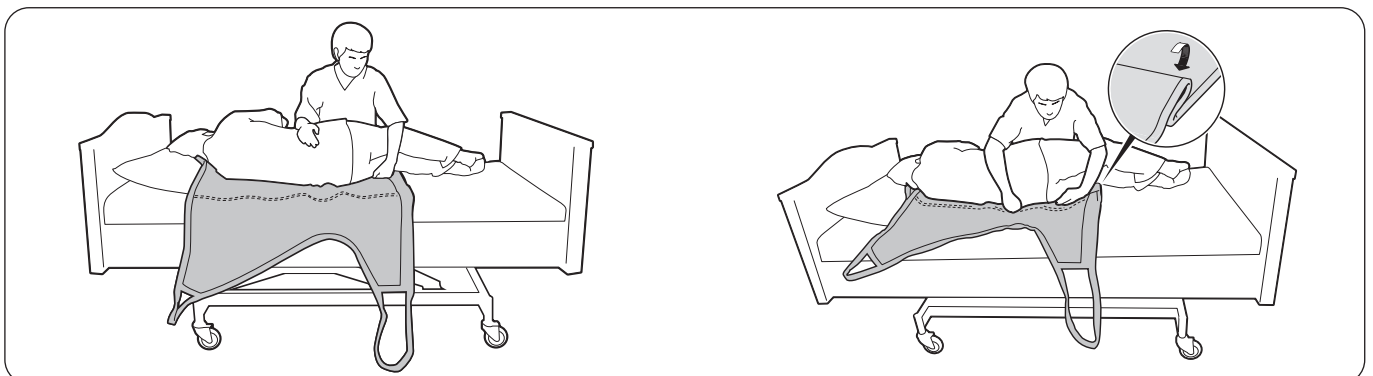

Turn the patient toward you to prevent him or her from falling out of the bed. Place the edge of the sling as far in under the patient as possible, and with its lower edge just below the bend in the patient's knees.

Fold the sling a couple of times so that its center back strap follows the patient's backbone when the patient is carefully rotated back.



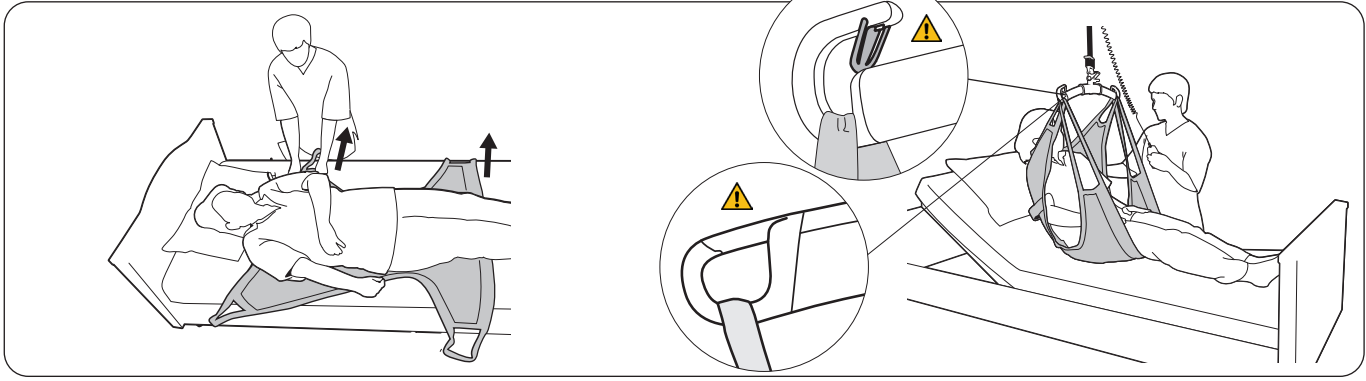

Carefully work the sling out on the other side. Make sure the patient is positioned in the middle of the sling. Adjust the position as needed. The lower edge of the sling should be just below the bend in the patient's knees.

Raise the back support. First connect the upper strap loops to the sling bar, then the lower strap loops. See page 6-7 for instructions on how to attach the sling loops to different sling bars. Lift the patient. Once the patient is lifted, the sling's lower edge will be placed approx. 0-10 cm (0-3.9 inch.) above the bend in the knees.

**An alternate method for applying the sling:** For patients who cannot be turned on their sides, sliding sheets can be used to apply the sling in the supine position. Place two sliding sheets under the patient, and apply the sling by pulling it between the sliding sheets. Contact your local Hill-Rom representative for more information.

## Returning to the Supine Position

Think about your own work posture as well as the comfort of the patient. Use the bed's raising and lowering functions. Lower the patient onto the bed and disconnect the sling's strap loops from the sling bar.

## Removing the Sling



Fold the sling in under itself and press it in as far under the patient as possible.

Carefully turn the patient towards you. **Hint:** Use the sling in order to facilitate the turn. Carefully pull away the sling.

## Lifting from the Floor

When lifting from the floor, we recommend Liko ComfortSling Plus High Mod. 350, which provides good head support.



## Lifting to a Wheelchair

When placing a patient in a wheelchair, it is important that the patient is far back in the chair in order to sit well. There are several ways to accomplish this.

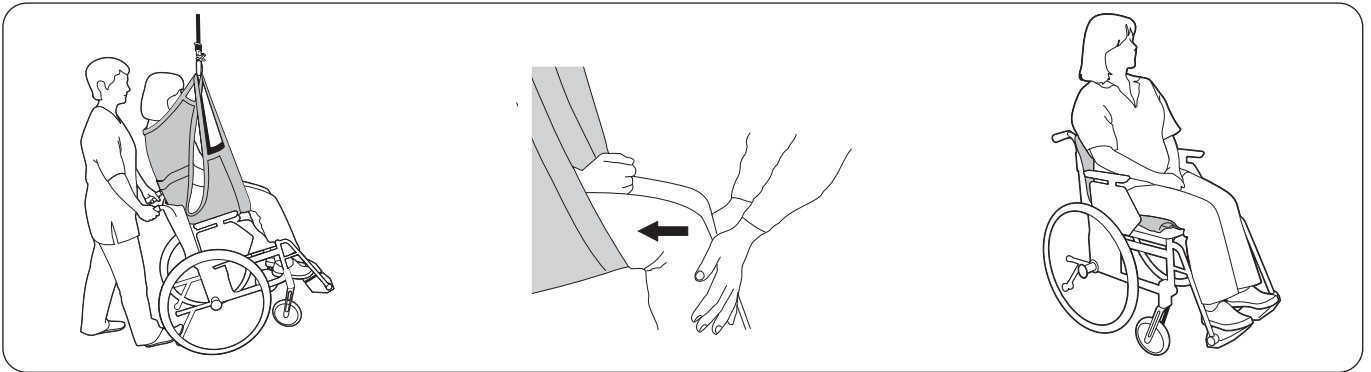

In order to facilitate placement in the wheelchair, the chair can be leaned back during the lowering sequence. Let the buttocks slide down along the back support for the final part. Monitor the location of the wheelchair with your foot on the tipping protection plate.

An alternate method is to apply slight pressure under the patient's knees during the lowering sequence so that the buttocks are pressed in against the back support. If there is a handle on the sling, this can be used to steer.

After a completed lift to a chair or wheelchair, disconnect the strap loops from the sling bar and fold the sling out of the way.

**⚠ NOTE! Excessive force on the handles can cause the sling to tear. Do not use the handles to lift!**

## Lifting from a Wheelchair

**⚠ Make sure that the sling is placed correctly before transferring the patient from the wheelchair.**

Sometimes, the patient may have shifted forward in the wheelchair, and on the sling as well. The sling should cover at least half of the bottom of the thigh to ensure a safe lift. If this is not the case, the patient should be positioned manually to an appropriate position.

## Different Sitting Positions Depending on Choice of Sling Bar

Liko ComfortSling Plus, Mod. 300

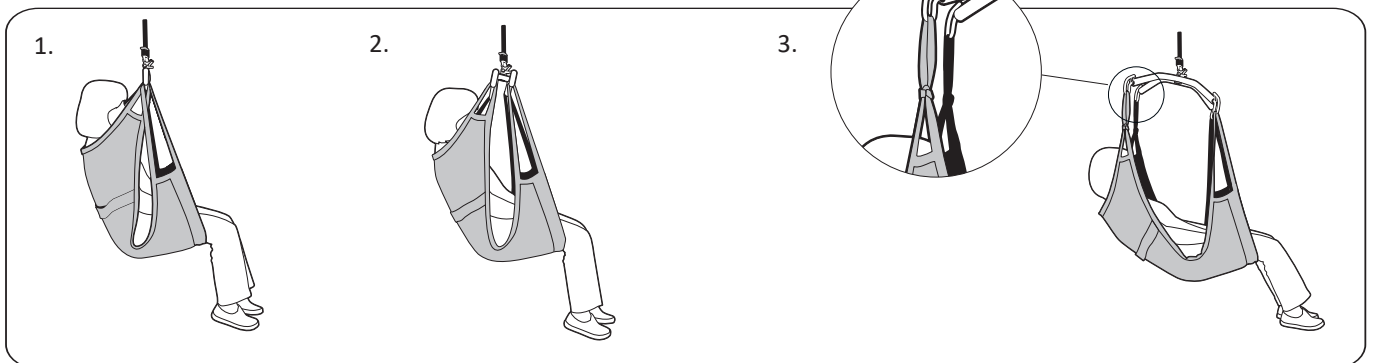

1. Liko ComfortSling Plus, Mod. 300 in combination with Liko Universal SlingBar 450 provides an upright sitting position.

2. Liko ComfortSling Plus, Mod. 300, in combination with a twin bar 670, provides a somewhat reclined sitting position as well as additional room for the shoulders.

3. Liko ComfortSling Plus, Mod. 300 in combination with Liko Sling Cross-bar 450 or 670 provides a reclined sitting position with less bend in the hip joint. Cross-bar 670 also provides additional room for the shoulders.

Liko Universal SlingBar 450 in combination with SideBars provides the same kind of reclined sitting position.

**⚠ For the combinations listed under point 3, 12 cm Extension Loops must **always** be used on the upper strap loops. When lifting, make sure that the lower edge of the sling is at the level of the bend in the knees. This also applies in combination with the older Liko Sling Cross-bar.**

## Liko ComfortSling Plus High, Mod. 350

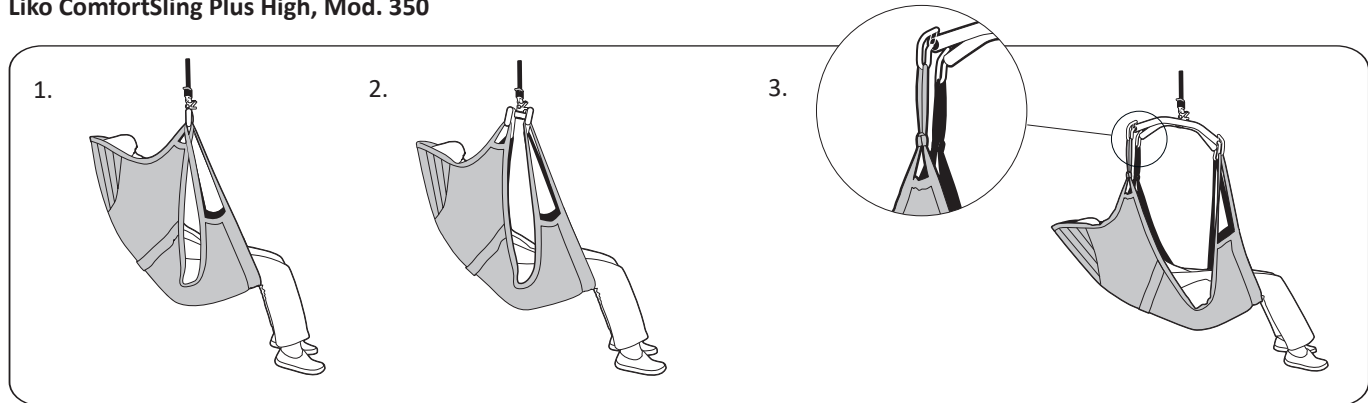

1. Liko ComfortSling Plus, Mod. 350 in combination with Liko Universal SlingBar 450 provides a comfortable, reclined sitting position.

2. Liko ComfortSling Plus, Mod. 350 in combination with a twin bar 670, provides a reclined sitting position as well as less bend in the hips and more room for the shoulders.

3. Liko ComfortSling Plus, Mod. 350 in combination with Liko Sling Cross-bar 450 or 670, provides a reclined sitting position. Cross-bar 670 also provides additional room for the shoulders.

Liko Universal Slingbar 450 in combination with SideBars provides the same kind of reclined sitting position.

**⚠** For the combinations listed under point 3, 12 cm Extension Loops must **always** be used on the upper strap loops. When lifting, make sure that the lower edge of the sling is at the level of the bend in the knees. This also applies in combination with the older Liko Sling Cross-bar.

## Different Sling Bars

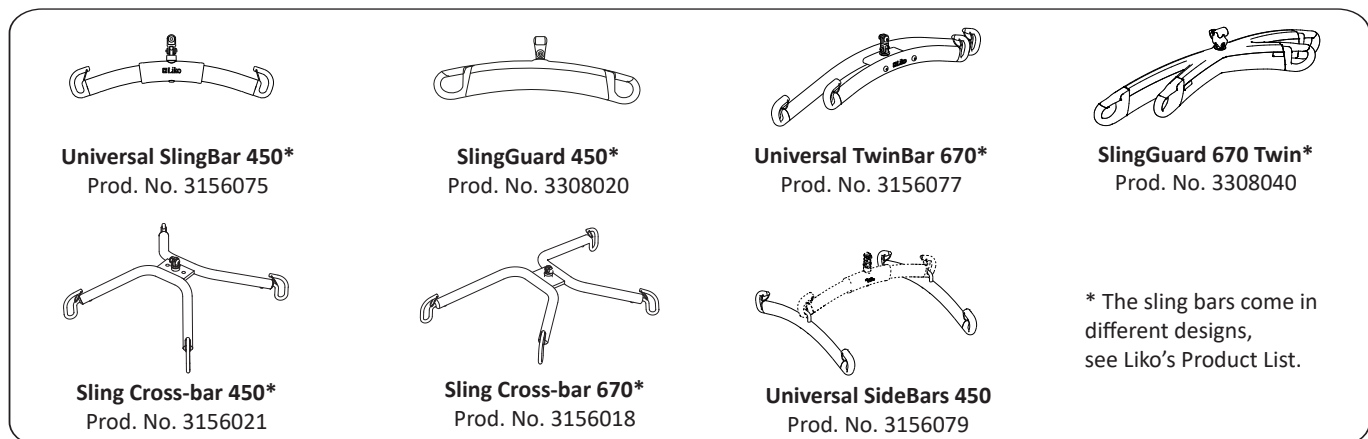

## Accessories

- Extension Loop, green, 12 cm (5 in)
- Extension Loop, green 22 cm (9 in)
- Extension Loop, grey, 12 cm (5 in)
- Extension Loop, grey, 22 cm (9 in)

- Prod. No. 3691102
- Prod. No. 3691103
- Prod. No. 3691302
- Prod. No. 3691303

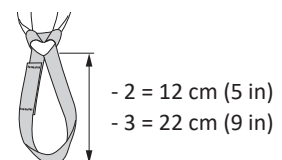

## Overview Liko™ ComfortSling Plus Mod. 300, 350

Product	Prod. No.	Size	Maximum load <sup>1</sup>
Liko ComfortSling Plus, Mod. 300	35300304	S Small	200 kg (440 lbs)
Liko ComfortSling Plus, Mod. 300	35300305	M Medium	200 kg (440 lbs)
Liko ComfortSling Plus, Mod. 300	35300306	L Large	200 kg (440 lbs)
Liko ComfortSling Plus, Mod. 300	35300307	XL Extra large	300 kg (660 lbs.)
Liko ComfortSling Plus High, Mod. 350	35350304	S Small	200 kg (440 lbs)
Liko ComfortSling Plus High, Mod. 350	35350305	M Medium	200 kg (440 lbs)
Liko ComfortSling Plus High, Mod. 350	35350306	L Large	200 kg (440 lbs)
Liko ComfortSling Plus High, Mod. 350	35350307	XL Extra large	300 kg (660 lbs.)

<sup>1</sup>For retained maximum load, lift/accessories intended for the same load or more are required.

Model	Size	Patient's weight <sup>2</sup>	Width (A)	Height (B)
300	S Small	25-50 kg (55-110 lbs)	47 cm (18.5 in.)	85 cm (33.5 in.)
300	M Medium	40-80 kg (88-176 lbs)	56 cm (22 in.)	100 cm (39.5 in.)
300	L Large	70-110 kg (154-243 lbs)	78 cm (31 in.)	121 cm (48 in.)
300	XL Extra large	> 100 kg (> 220 lbs)	80 cm (31.5 in.)	128 cm (50.5 in.)
350	S Small	25-50 kg (55-110 lbs)	47 cm (18.5 in.)	120 cm (47 in.)
350	M Medium	40-80 kg (88-176 lbs)	56 cm (22 in.)	136 cm (53.5 in.)
350	L Large	70-110 kg (154-243 lbs)	67 cm (26.5 in.)	145 cm (57 in.)
350	XL Extra large	> 100 kg (> 220 lbs)	67 cm (26.5 in.)	153 cm (60.5 in.)

<sup>2</sup>The indicated patient weight is only a guideline – there may be deviations.

If the patient has poor muscle tone and sinks too low in the ComfortSling, you should consider a smaller size.

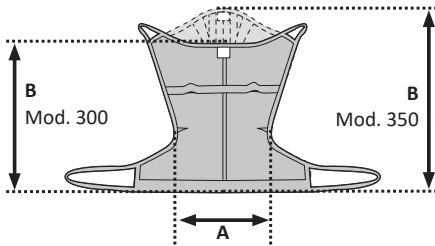

### Material

ComfortSling Plus is made of net polyester.

## Recommended Combinations

Recommended combinations of Liko™ ComfortSling Plus with Liko's sling bars:	Mini 220	Sling bar 350 <sup>4</sup>	Sling bar 450 <sup>2</sup>	Sling bar 600 <sup>5</sup>	Twin bars 670 <sup>3</sup>	Sling Cross-bar 450	Sling Cross-bar 670	Univ. SideBars + Universal 350	Univ. SideBars + Universal 450
ComfortSling Plus Mod. 300 S	2	1	1	4	4	1 <sup>1</sup>	4	1 <sup>1</sup>	1 <sup>1</sup>
ComfortSling Plus Mod. 300 M	2	2	1	2	1	1 <sup>1</sup>	1 <sup>1</sup>	1 <sup>1</sup>	1 <sup>1</sup>
ComfortSling Plus Mod. 300 L	3	2	1	1	1	1 <sup>1</sup>	1 <sup>1</sup>	1 <sup>1</sup>	1 <sup>1</sup>
ComfortSling Plus Mod. 300 XL	3	3	2	1	1	2 <sup>1</sup>	1 <sup>1</sup>	2 <sup>1</sup>	1 <sup>1</sup>
ComfortSling Plus Mod. 350 S	2	1	1	4	4	1 <sup>1</sup>	4	1 <sup>1</sup>	1 <sup>1</sup>
ComfortSling Plus High Mod. 350 M	3	2	1	1	1	1 <sup>1</sup>	1 <sup>1</sup>	1 <sup>1</sup>	1 <sup>1</sup>
ComfortSling Plus High Mod. 350 L	3	2	1	1	1	1 <sup>1</sup>	1 <sup>1</sup>	1 <sup>1</sup>	1 <sup>1</sup>
ComfortSling Plus High Mod. 350 XL	3	3	2	1	1	1 <sup>1</sup>	1 <sup>1</sup>	2 <sup>1</sup>	1 <sup>1</sup>

**Explanation:** 1 = Recommended, 2 = May work, 3 = Not advised, 4 = Inappropriate

<sup>1</sup>  Always use the Extension Loops 12 cm on the upper strap loops.

When sitting, the lower edge of the sling should be near the bend in the knees.

<sup>2</sup> Sling bar 450 relates to Universal SlingBar 450 Prod. No. 3156075, 3156085, and 3156095, SlingBar Standard 450 Prod. No. 3156001, 3156003, 3156007, and 3156016, and also SlingGuard 450 Prod. No. 3308020 and 3308520.

<sup>3</sup> Twin bars 670 relates to Universal TwinBar 670 Prod. No. 3156077, and 3156087, and also SlingGuard 670 Twin Prod. No. 3308040 and 3308540.

<sup>4</sup> Sling bar 350 relates to Universal SlingBar 350 Prod. No. 3156074, 3156084, and 3156094.

<sup>5</sup> Sling bar 600 relates to Universal SlingBar 600 Prod. No. 3156076 and 3156086.

For combinations with other Liko sling bars, please contact Hill-Rom.

### Other combinations

Combinations of accessories/products other than those recommended by Liko can result in risks for the safety of the patient.



[www.hillrom.com](http://www.hillrom.com)

Liko AB  
Nedre vägen 100  
975 92 Luleå, Sweden  
+46 (0)920 474700

Liko AB is a subsidiary of Hill-Rom Holdings Inc.

Enhancing outcomes for  
patients and their caregivers:

